

KM070 series

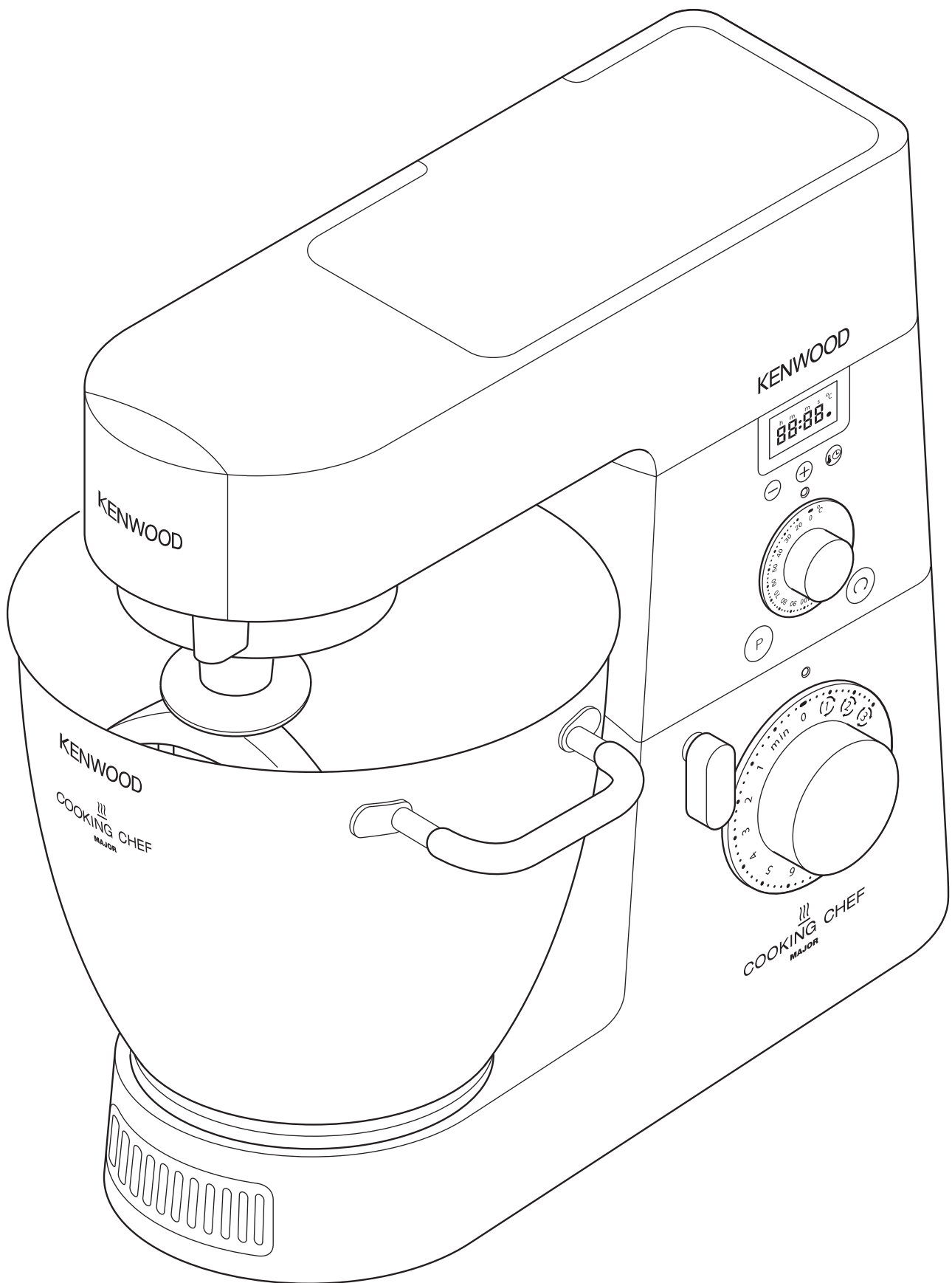

KENWOOD

before using your Kenwood appliance

- **Read these instructions carefully and retain for future reference.**
- Remove all packaging and any labels.

know your Kenwood Cooking Chef Kitchen Machine

safety

important note - electronic medical implants

- Like all induction heating products, this appliance generates short-range magnetic fields. If any user or person in close proximity has a pacemaker or other active implants, please consult a doctor before use, concerning any possible incompatibility to prevent any risk to health.
- Switch off and unplug the appliance before fitting or removing tools/attachments, after use and before cleaning.
- Keep body parts, jewellery and loose clothing away from moving parts and fitted attachments.
- Never put your fingers etc., into the hinge mechanism.
- Never leave the appliance on unattended.
- Never use a damaged appliance. Get it checked or repaired: see 'service and customer care', page 16.
- Never use an unauthorised attachment or more than one attachment at once.
- Never exceed the maximum capacities on page 13 and when using the induction heater never exceed the 3 litre maximum fill level marked on the inside of the bowl.
- When using an attachment, read the safety and usage instructions that come with it.
- Take care when lifting this appliance as it is heavy. Ensure the head is locked and that the bowl, tools, outlet covers and cord are secure before lifting.
- Never let the cord hang down where a child could grab it.
- Never let the power unit, cord or plug get wet.
- Be careful when handling or touching any part of the appliance when being used in the cook mode or after cooking, IN PARTICULAR THE BOWL, SPLASHGUARD AND TOOLS as they will remain HOT long after the appliance has been switched off. Use the handles to remove and carry the bowl. Use oven gloves when handling the hot bowl and hot mixing tools.
- The underside of the bowl will remain hot long after the heating has stopped. Use caution when handling and use the work surface protection mat when placing the bowl on heat sensitive surfaces.
- Be careful of steam escaping from the mixer bowl particularly when opening the lid in the splashguard or when raising the mixer head.
- If transferring hot food from the mixer to the liquidiser, always allow the ingredients to cool to room temperature before placing in the liquidiser.
- Only use the bowl and tools supplied with this appliance. Never use the bowl with any other heat source.
- Never operate the appliance in the cook mode with the bowl empty.
- Never insert anything through the air vents.
- When using this appliance ensure it is positioned on a level surface away from the edge. Make sure it is at least 10 cm from walls and ensure that the vents are not blocked. Do not position below overhanging cupboards.
- For the correct and safe operation of the induction cooker ensure that the bowl base and temperature sensors are clean and dry before cooking.
- As with all induction cooking appliances do not place credit cards, magnetic media or sensitive electronic equipment near to the appliance when in use.
- Do not use the appliance for deep frying foods.
- Always ensure food is thoroughly cooked before eating.
- Food should be eaten shortly after cooking or allowed to cool quickly and then refrigerated as soon as possible.
- This appliance is not intended for use by persons (including children) with reduced physical, sensory or mental capabilities, or lack of experience and knowledge, unless they have been given supervision or instruction concerning use of the appliance by a person responsible for their safety.
- Children should be supervised to ensure that they do not play with the appliance.
- Only use the appliance for its intended domestic use. Kenwood will not accept any liability if the appliance is subject to improper use, or failure to comply with these instructions.

- important - UK only
- **before plugging in**
 - Make sure your electricity supply is the same as the one shown on the underside of your machine.
 - The wires in the cord are coloured as follows:
 - Green and Yellow = Earth, Blue = Neutral, Brown = Live.
 - The appliance must be protected by a 13A approved (BS1362) fuse.
 - **WARNING: THIS APPLIANCE MUST BE EARTHED.**

Note:

- For non-rewireable plugs the fuse cover **MUST** be refitted when replacing the fuse. If the fuse cover is lost then the plug must not be used until a replacement can be obtained. The correct fuse cover is identified by colour and a replacement may be obtained from your Kenwood Authorised Repairer (see Service).
- If a non-rewireable plug is cut off it must be **DESTROYED IMMEDIATELY**. An electric shock hazard may arise if an unwanted non-rewireable plug is inadvertently inserted into a 13A socket outlet.
- This appliance conforms to EC directive 2004/108/EC on Electromagnetic Compatibility and EC regulation no. 1935/2004 of 27/10/2004 on materials intended for contact with food.

before using for the first time

Wash the parts: see 'care and cleaning' page 16.

introduction

Thank you for buying this Kenwood Cooking Chef Kitchen Machine, we hope you will enjoy many years use.

Kenwood has nearly 60 years of experience and expertise in developing our Kitchen Machines and their wide variety of attachments. Kenwood Chef Kitchen Machines are renowned for being more than just a food mixer.

In the development of Cooking Chef we have taken the well-known versatility of the Chef a step further by introducing integrated Induction Cooking directly beneath the mixing bowl. You can now enjoy all of the benefits of everyday 'cold bowl' planetary mixing when preparing your favourite cakes, pastries and dough, plus the added advantage of heating and cooking directly in the bowl combined with planetary mixing. The opportunities are endless.

The Kenwood Cooking Chef with its range of optional attachments truly is the complete food preparation system.

Strong, Reliable, Versatile, Kenwood.

What is Induction Cooking and how does it work?

Induction cooking is an advanced cooking method that employs the principles of electromagnetic induction. When an electric current is passed through a copper coil in the induction cooking area it creates an electro-magnetic field. When the Cooking Chef bowl is locked into position the circuit is completed by a special layer of stainless steel in the bowl base. In turn this creates a large amount of thermal energy that passes through to the contents of the bowl, thus heating the food.

Induction cooking is extremely energy efficient because it only produces heat in the base of the bowl. Other heating methods such as gas hobs waste almost 50% of the heat energy around the sides of the pan. Indeed the Induction cooking area on your Cooking Chef only feels hot during and immediately after cooking because of the heat transferred back from the contents of the bowl. All of this means that Induction cooking is very efficient, very safe and very clean.

The cooking functionality of your Kenwood Cooking Chef is similar to using a saucepan on your cooker hob. The added advantage is that the Chef will automatically stir your food and regulate the cooking temperature to your precise requirements, leaving you free to confidently perform other tasks in your kitchen.

The Cooking Chef uses induction heating technology which is extremely efficient. When compared to cooking on a gas or electric hob, you may find that cooking times are reduced or that you need to cook on a lower temperature. This should be considered when using your appliance for the first time or when experimenting with a new recipe. Make sure that if you start cooking at a high temperature, you keep watching and reduce the heat when necessary to stop food burning and sticking to the bowl, just as you would with your saucepan. Generally the Cooking Chef will automatically heat the food to your desired temperature in the quickest possible time. It is therefore not necessary to set the temperature higher than you require in order to reduce cooking times. At this stage you should also pay attention to the frequency of the stir settings. When cooking at higher temperatures you may find it necessary to stir constantly using stir setting (1). Stir settings (2) and (3) are useful in maintaining the consistency of your food during longer cooking periods on a low simmer.

Selection of the correct bowl tool is also important at this stage. Further on in this book we have suggested the most appropriate uses for each tool and with experience you will quickly understand which is best for each task. When cooking you will find that the high temperature flexible beater is best used to obtain a very smooth consistency for sauces and creams, whereas the stirring tool is better when cooking foods that need to maintain a more solid consistency, such as stews, casseroles, ragouts etc. Our recipe book recommends the best tools for each recipe, and you may also find that changing the tool for different processes during your meal preparation gives better results.

During cooking and immediately afterwards, the bowl, splashguard and bowl tool will be hot – just as your saucepan would be. Please take care when touching any of these. It is important to also remember that the cooking process will generate steam and condensation so take care when looking into the bowl, lifting the food chute lid or the Cooking Chef/machine head to view or access the bowl. You should also warn others when the machine is cooking or hot so they will also be careful. When touching or removing hot parts it is advised to use oven gloves and only carry the bowl using the handles provided. You may also find the work surface protection mat useful to protect heat sensitive surfaces.

When heating liquids or food with a high water content, the accuracy of the temperature reading is usually within +/- 5°C. The accuracy of the temperature display and control will vary depending upon the consistency of your bowl contents, the volume of your bowl contents, the frequency of stirring and the bowl tool that is used. Again this is similar to cooking on a hob, for example, where a large quantity of food in a large saucepan is heated but not stirred thoroughly. The food will be hot at the base of the saucepan, or even burnt, whereas the food near the top will be much cooler.

In addition to the temperature display the machine has a small blue LED. This will flash until the machine has reached the selected temperature. Once the required temperature is reached the light will stop flashing. However, you should note that when you add further ingredients to the bowl the blue LED will begin to flash again as the temperature of the bowl contents will be reduced by cold ingredients. You may also notice the static light begin to flash if the mixing frequency is increased.

You will quickly find that your Kenwood Cooking Chef is simple to use and will help make your everyday food preparation easy.

know your Kenwood Cooking Chef

- attachment outlets
- 1 high speed outlet
 - 2 medium speed outlet
 - 3 slow speed outlet
 - 4 tool socket
- the mixer
- 5 medium/high speed outlet cover
 - 6 mixer head
 - 7 slow speed outlet cover
 - 8 slow speed outlet lever
 - 9 cooking chef bowl
 - 10 head - lift lever
 - 11 speed control
 - 12 air vents
 - 13 bowl pedestal/induction area
 - 14 drain hole
 - 15 temperature sensors
 - 16 stainless steel K beater
 - 17 high temperature flexible beater
 - 18 flexible wiper
 - 19 whisk
 - 20 dough hook
 - 21 stirring tool
 - 22 high temperature spatula
 - 23 heat shield
 - 24 rubber seal
 - 25 splashguard
 - 26 feed chute lid
 - 27 work surface protection mat
 - 28 spanner

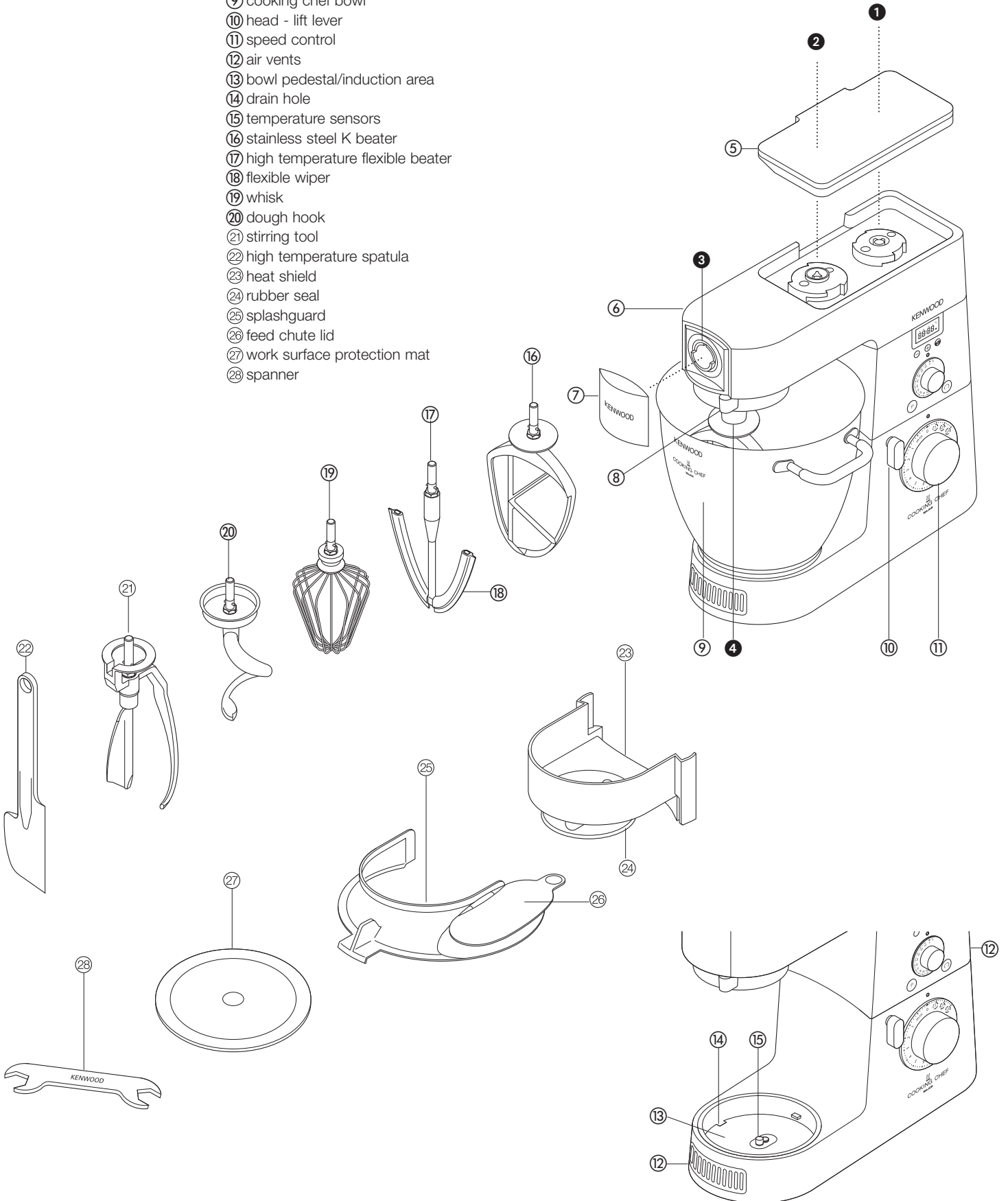

control panel

- ① timer/temperature display
- ② timer decrease button
- ③ timer increase button
- ④ temperature control
- ⑤ pulse button/high speed, high temperature whisk button
- ⑥ speed control
- ⑦ timer/temperature selector button
- ⑧ temperature indicator light
- ⑨ fold button
- ⑩ speed control indicator light

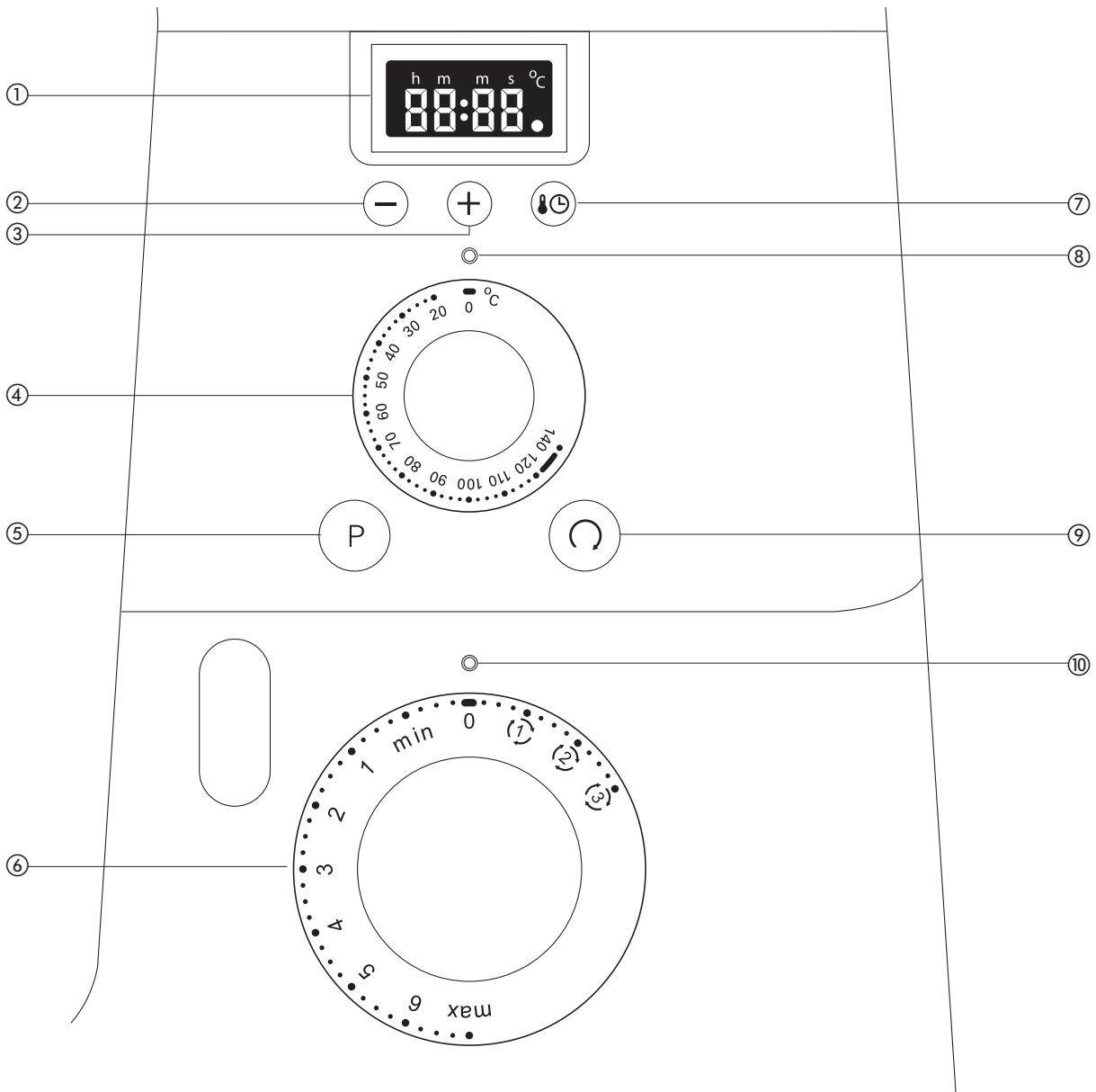

adjusting the height of the tools

Please refer to page 9 on how to assemble the mixer.

whisk, stainless steel K beater, stirring tool

For best performance the whisk, K beater and stirring tool should be **almost** touching the bottom of the bowl ❶. If necessary adjust the height using the spanner provided.

Here's how:

- 1 Unplug the appliance.
- 2 Raise the mixer head and insert the whisk, beater or stirring tool.
- 3 Lower the mixer head. If the clearance needs to be adjusted, raise the mixer head and remove the tool.
- 4 Using the spanner provided loosen the nut ❷ sufficiently to allow adjustment of the shaft ❸. To lower the tool closer to the bottom of the bowl, turn the shaft anti-clockwise. To raise the tool away from the bottom of the bowl turn the shaft clockwise.
- 5 Re-tighten the nut.
- 6 Fit the tool to the mixer and lower the mixer head. (Check its position see points above).
- 7 Repeat the above steps as necessary until the tool is set correctly. Once this is achieved tighten the nut securely.

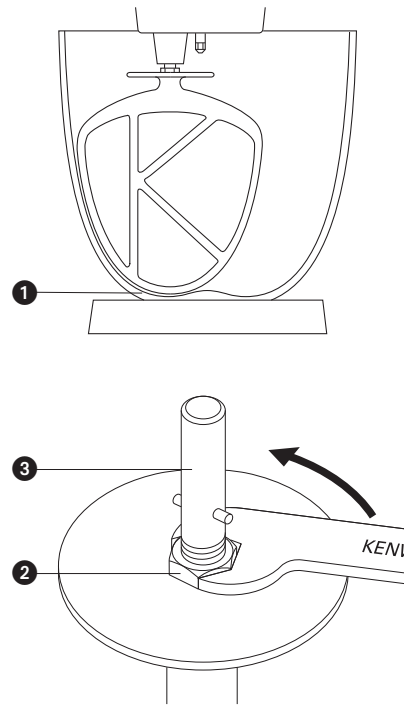

high temperature flexible beater - this tool should just touch the bottom of the bowl.

dough hook - this tool is set at the factory and should require no adjustment.

to fit and use your splashguard assembly

The splashguard assembly consists of 2 pieces: the heat shield and the splashguard.

The heat shield must be fitted during cooking operations otherwise the mixer will not operate and error code E:03 will be displayed. The heat shield is to protect the mixer head from steam produced during the cooking process.

If necessary both the heat shield and the splashguard can be fitted to retain ingredients in the bowl e.g. when mixing light ingredients such as flour and icing sugar, or when cooking ingredients where moisture needs to be retained in the bowl. The splashguard should not be fitted to the bowl unless used in conjunction with the heat shield.

- 1 Raise the mixer head until it locks.
 - 2 Push the heat shield upwards onto the underside of the mixer head ❶ until fully located. The heat shield must never be used without the rubber seal correctly fitted.
 - 3 Fit the bowl onto the base.
 - 4 Lower the mixer head.
 - 5 Rest the splashguard on the bowl rim and then slide forward until fully located ❷.
- During mixing, ingredients can be added directly to the bowl via the feed chute.
- 6 To remove the splashguard simply slide it away from the appliance.
 - 7 To remove the heat shield, raise the mixer head until it locks. Remove the tool, then pull the heat shield downwards from the underside of the mixer head.

Note: Only fit or remove the splashguard when the mixer head is in the locked position.

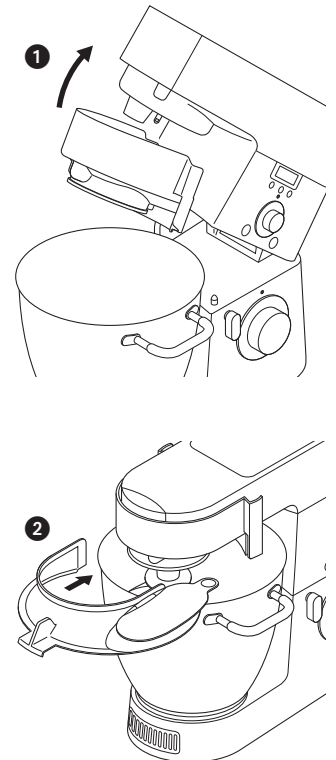

the mixer

the mixing tools and some of their uses

- K-beater ● For making cakes, biscuits, pastry, icing, fillings, éclairs and mashed potato.
- whisk ● For eggs, cream, batters, fatless sponges, meringues, cheesecakes, mousses, soufflés. Don't use the whisk for heavy mixtures (e.g. creaming fat and sugar) - you could damage it.
- dough hook ● For yeast mixtures only.
- high temperature flexible beater ● Suitable for many cooking operations in particular cooking custards, scrambled eggs and sauces. Ideal for scraping mixes both hot and cold from the sides of the bowl during mixing. Also suitable to sauté vegetables.
- stirring tool ● Suitable to use during cooking to maintain the consistency of food e.g. chicken, fish, vegetables and fruit.

to use your mixer

Before using the mixer ensure the temperature and speed controls are switched to the off 'O' positions.

- 1 Turn the head-lift lever clockwise ❶ and raise the mixer head until it locks.
- to fit a tool 2 Place the tool in the socket, locating the shaft pin in the groove and then turn to lock into position ❷.
- stirring tool** - to fit the stirring tool, insert the shaft into the socket, then line up the slot on the extension so that it is located beneath the metal pin on the underside of the mixer head. Hold the paddle and turn so that the shaft pin is below the groove then push up and turn to lock into position ❸.
- 3 Fit the bowl onto the base - press down and turn clockwise ❹.
- 4 To lower the mixer head, raise it slightly, then turn the head lift lever clockwise. Lower into the locked position.
- to remove a tool ● Reverse step 2 above. (Always use oven gloves to remove tools after cooking).
- 5 Connect the mixer to the power supply. The speed and temperature indicator lights will illuminate briefly. The display will show **88:88** and then clear leaving the power on indicator illuminated .
- 6 Turn the speed control to the desired setting (see page 10 for recommendations), the mixer will start and the speed control indicator light will flash. The timer will count up in 1 second intervals. The speed can be changed at any time whilst the mixer is operating.
- 7 Stop the mixer by returning the speed control to the off 'O' position.

Important - If at any time, the mixer head is raised during an operation, the mixer will automatically stop and beep and it will not re-start when the mixer head is lowered. To re-start the mixer turn the speed control to the off 'O' position and then re-select a speed.

pulse button

The pulse button can only be used when the speed control is in the off 'O' position.

To select pulse, press the pulse button **P** and the mixer will run at maximum speed for as long as the button is held in this position. If the bowl contents are above 60°C, the speed will increase gradually. This will be accompanied by a beeping sound and the speed and temperature indicator lights will flash quickly.

fold button

Press and release the fold button **F** and the mixer will automatically operate on minimum speed for 2 revolutions and then stop. The button can be pressed for a longer operation or pressed repeatedly as needed to combine ingredients.

Note: If the fold button is pressed whilst the motor is running it will perform the standard fold function and then return to the selected speed.

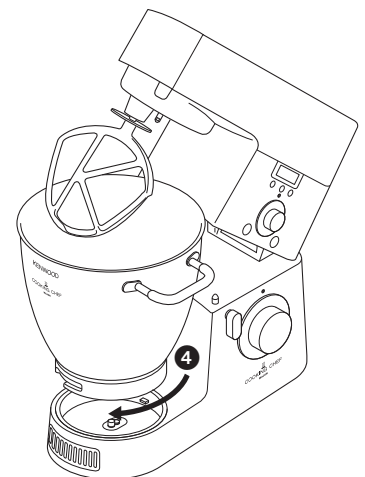
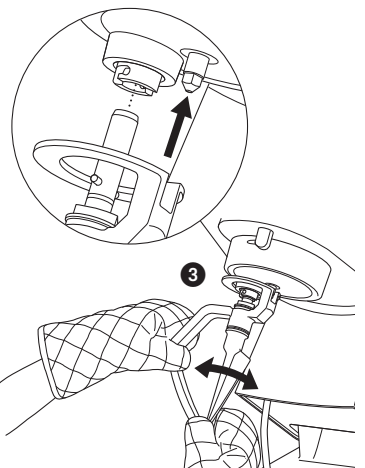
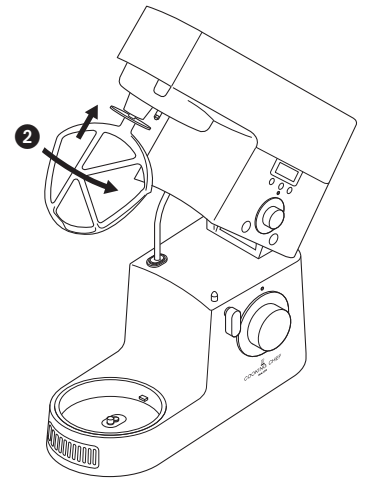
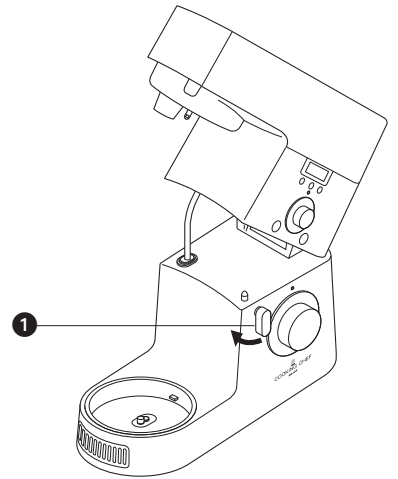

speed control 5

The following speeds are a guide only and will vary depending upon the quantity and the temperature of the ingredients being mixed etc. Turn the speed control clockwise to obtain speeds 'min' through to 'max'.

- K-beater
 - **creaming fat and sugar** start on min, gradually increasing to 'max'.
 - **beating eggs into creamed mixtures** 4 - 'max'.
 - **folding in flour, fruit etc** min - 1
 - **all in one cakes** start on min speed, gradually increase to max.
 - **rubbing fat into flour** min - 2.
- high temperature flexible beater
 - **creaming fat and sugar** start on min, gradually increasing to 3.
 - **scraping mixes both hot and cold from the sides of the bowl** start on min gradually increasing to 3.
 - **sauteing vegetables, stirring risotto and polenta etc.,** use (1).
- whisk
 - Gradually increase to 'max'.
- dough hook
 - Start on 'min', gradually increasing to 1.
- stirring tool
 - Use with the stir settings only (1), (2), (3).

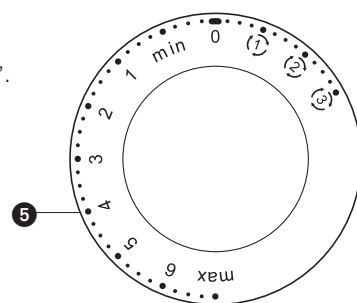

stir settings

To select the stir settings turn the speed control anti-clockwise. These are most suitable when the mixer is used in the cook mode. Please note, to use the stir speeds all outlet covers must be fitted.

- (1) – Use this setting when a constant slow speed is required e.g. stirring sauces.
- (2) – When the speed control is set to this position, the mixer will intermittently operate on a slow speed once every 5 seconds for approximately 2 revolutions.
- (3) – When the speed control is set to this position, the mixer will intermittently operate on a slow speed once every 30 seconds, making it suitable for stirring casseroles etc.

Return the speed control to the off 'O' position to stop the operation.

Note:

- Whenever a speed is selected, the speed indicator light will flash.
- A high pitched sound may be heard from the appliance when in use. This is normal.

to use the mixer to cook food

IMPORTANT

- Make sure the induction area, temperature sensors and external surface of the bowl base are clean. Failure to do this will affect the heat sensor, resulting in poor cooking performance.
- Check that all the outlet covers including the heat shield are fitted. If they are not correctly fitted the heating function will not operate.
- Always use oven gloves to remove the bowl and tools after cooking.

- 1 Assemble the mixer following the instructions on page 9.
- 2 Turn the temperature control to the required temperature.
 - **Heating will not commence unless a speed is selected.**
- 3 Turn the speed control to the desired speed which will switch on the motor and the heater. Both indicator lights will flash.
- 4 Once the set temperature is reached, the temperature indicator light will illuminate continuously. However, during cooking the light will start to flash if the temperature changes indicating that the mixer is trying to maintain the set temperature (please read introduction page 4).
 - If the bowl temperature exceeds 60°C, for safety reasons the speed is automatically limited even if a higher speed has been selected. The speed will not automatically increase when the temperature drops below 60°C. The speed control must be switched off first and the desired speed reselected.
 - Note: Each time the timer/temperature selector button is pressed, the display will alternate between the timer display and the temperature of the bowl contents.
- 5 To stop or pause the mixing and heating process, return the speed control to the off 'O' position. To resume the operation select a speed.

hints

- **Some recipes, in particular those with a high water content, will not be able to reach a cooking temperature above 100°C (as this is the boiling point of water).**
- When adding ingredients to the bowl during cooking, turn the speed down and add the ingredients slowly and evenly.
- To heat sauces quickly use a continuous stir setting (T).
- You may find changing the tool for different processes during your meal preparation gives better results e.g. use the high temperature flexible beater to fry vegetables and then the stirring tool whilst cooking pieces of meat or poultry.
- If using the splashguard during cooking, always remove it before lifting the mixer head. Be aware of condensation formed on the splashguard and heat shield.
- When lifting the mixer head lift it slowly to allow any liquid on the underside of the heat shield to flow back into the bowl.
- Three stir functions are available which enable you to select the appropriate amount of stirring for individual recipes. Some recipes will require constant stirring to stop ingredients from sticking to the bottom of the bowl, whereas others will benefit from intermittent stirring to maintain the consistency of the food.
- For optimum performance adjust the tool heights see page 8.
- The maximum cooking time is 3 hours after which time the mixer will automatically switch off.
- It is possible to heat food without a tool in position, however a speed must be selected. This may be advantageous when melting foods e.g. butter, chocolate.
- Each time the timer/temperature selector button is pressed the display will alternate between displaying the cooking time and the temperature reached at that point.

High speed, high temperature whisk control

To whisk at high speed at temperatures above 60°C, turn the speed control to the desired whisking speed and then press and hold the pulse button. This will be accompanied by a beeping sound and the speed and temperature indicator lights will flash quickly. The whisking speed will slowly increase to the selected speed. Repeat the procedure to increase the speed further. You can reduce the whisking speed or turn off the mixer as normal.

This function MUST only be used with the whisk. You should not exceed the maximum cooking capacity of 3 litres and you must ensure the splashguard is fitted. The machine must not be left unattended.

after cooking

- Be careful when handling or touching any part of the mixer when being used in the cook mode or after cooking, IN PARTICULAR THE BOWL, SPLASHGUARD AND TOOLS as they will remain HOT long after the appliance has been switched off. Use the handles to remove and carry the bowl. Use oven gloves when handling the hot bowl and hot mixing tools.
- The underside of the bowl will remain hot long after the heating has stopped. Use caution when handling and use the work surface protection mat provided to protect heat sensitive surfaces.

display

For your safety the mixer is fitted with 5 separate safety sensors which will operate when using the mixer in the cooking mode. If the mixer is switched on and a safety sensor activated, the timer/temperature display will show an error message e.g. 'E:01'. This will be accompanied by a beeping sound and the mixer will not work. Check the following error messages:-

Error Message	Description	Solution
E:01	The head of the machine is in the raised position. When the head is lifted, a safety sensor disables the motor and heater. If the speed control is turned to any setting other than the Off 'O' position when the head is raised, this message is displayed and the motor will not switch on.	Close the head. Turn the speed control to the 'O' position and then select the desired speed.
E:02	The Cooking Chef Bowl is not fitted. The heating function will only work if the Cooking bowl is being used. This bowl must also be correctly fitted. Safety sensors will detect an incorrect bowl or the correct bowl incorrectly fitted.	Ensure that the Cooking Chef bowl is being used. Check that the bowl is fitted correctly. Turn the speed control to "O" and then select desired speed.
E:03	The heat shield is not fitted. The heating function will be disabled if the heat shield is not correctly fitted.	Ensure the heat shield is fitted correctly. Turn the speed control to 'O' and then select desired speed.
E:04	The slow speed outlet and high speed/medium speed outlet covers are not fitted. These covers are fitted with safety sensors. If the covers are not fitted correctly the heating will switch off and if stir functions are selected, the motor will run continuously. Mixing speeds min to max will run continuously.	Ensure that all covers are fitted correctly. Turn the speed control to 'O' and then select desired speed.
E:09	Temperature sensor problem. If the heater control detects a bowl temperature higher than expected during normal use, the motor and heater will automatically switch off.	Turn the speed control to 'O', unplug the machine and allow to cool. Check that the bowl base and temperature sensors are clean. Replace plug and switch on as normal.
E:10	Motor speed or overheat problem. If the motor stalls or gets too hot, the control system will automatically switch off the motor and heater.	Turn the speed control to 'O' and unplug the machine. Remove any obstructions causing the motor to stall. Ensure all the air vents are clear of obstructions. Plug in and switch on.

If these or any other error codes continue to appear on the display contact Kenwood Customer Care.

to use the countdown timer

The timer can be used in both the cooking and non cooking modes. If a countdown time is not selected, the timer will automatically count up in 1 second intervals whilst the mixer is in operation. The maximum running time is 3 hours.

- 1 Connect the mixer to the power supply. The display will briefly show **88:88.** and then clear leaving the power on indicator visible .
- 2 Press either the + or – button and 0:00 will appear in the display.
- 3 Press either the + or – button until the desired time is displayed. The timer will count up in 5 second intervals. If the button is pressed continuously the numbers will change more quickly the longer it is held down. A maximum time of 3 hours can be set.
Note: If the + button is pressed when the timer is at 3:00 the displayed time will change to 0:00. If the – button is pressed when the timer is at 0:00 the displayed time will change to 3:00.
- 4 Turn the speed control to the desired speed, the mixer will start and the timer will count down in 1 second intervals.
 - The mixer operation can be paused at any time by turning the speed control to the off 'O' position. This will also pause the timer. The timer will continue to count down when the mixer is re-started.
- 5 The mixing process will automatically stop when the total time has elapsed and audible beeps will be emitted for 3 seconds. The display will flash for 5 seconds and then clear showing the power on indicator .

to reset the timer

- 1 Zero the timer by pressing the + and – buttons at the same time (the speed control must be in the off 'O' position).
 - If the machine has been idle for 10 minutes, the LCD display and backlight will enter 'sleep mode' and all the displays will turn off. If any button or control knob is activated, the display will resume its previous format.

maximum capacities

- shortcrust pastry** • Flour weight: 910g - 2lb
- stiff yeast dough** • Flour weight: 1.5kg - 3lb 5oz
- Total weight: 2.4kg - 5lb 5oz
- soft yeast dough** • Flour weight: 2.6kg - 5lb 12oz
- Total weight: 5kg - 11lb
- fruit cake mix** • Total weight: 4.55kg - 10lb
- egg whites** • 16
- cooking mode** • 3 litres

- general hints
- Stop mixing and scrape down the bowl with the spatula frequently.
 - Eggs at room temperature are best for whisking.
 - Before whisking egg whites, make sure there's no grease or egg yolk on the whisk or bowl.
 - Use cold ingredients for pastry unless your recipe says otherwise.

points for bread making

- important
- Never exceed the maximum capacities stated - you'll overload the machine.
 - If you hear the machine labouring, switch off, remove half the dough and do each half separately.
 - The ingredients mix best if you put the liquid in first.

trouble shooting guide when cooking

Problem	Cause	Solution
The mixer will not operate in the heat mode and displays an error message and gives a warning beep.	One of the safety sensors has been activated.	See the table referring to error messages page 12. <ul style="list-style-type: none"> • Ensure the head is lowered and locked. • Ensure all outlet covers are correctly fitted. • Ensure the heat shield is correctly fitted. • Ensure the cooking chef bowl is corrected fitted.
A temperature has been selected but the bowl contents do not heat (the temperature indicator light is not illuminated).	A speed has not been selected.	Select a speed.
The mixer changes speed during cooking.	The speed is automatically limited when the bowl contents reach 60°C.	This is a safety feature.
Food burning on the base of the bowl.	<ol style="list-style-type: none"> 1 The temperature setting selected may be too high. 2 Incorrect tool being used. 3 The stir function is too slow. 4 The tool may not be low enough in the bowl. 5 The timer has been set for too long. 6 The sensor and/or the underside of bowl may not be clean. 	<ol style="list-style-type: none"> 1 Reduce the temperature on the dial or cook at a lower temperature. 2 Check the most suitable tool is being used. 3 Increase the frequency of the stir function or increase to a continuous operation. 4 Adjust the tool. 5 Cook for a shorter length of time (ensure food is thoroughly cooked). 6 Ensure that these areas are kept clean and dry.
Consistency of food not maintained.	<ol style="list-style-type: none"> 1 Temperature selected too high. 2 Stir function too fast. 3 Ingredients cooked for too long. 4 Incorrect tool being used. 	<ol style="list-style-type: none"> 1 Reduce temperature. 2 Reduce stir speed. 3 Reduce the cooking time (ensure food is thoroughly cooked). 4 Check the most suitable tool is being used.
Inconsistent mixing speed.	<ol style="list-style-type: none"> 1 Ingredients too large, hard or too firm. 	<ol style="list-style-type: none"> 1 Cut food into smaller pieces, remove stones from fruit, slowly melt ingredients without a tool in position (but ensure a speed has been selected). 2 Add ingredients after the head is lowered. 3 Check the most suitable tool is being used.
Cold ingredients have been added to a hot mixture but the temperature display does not respond quickly.	If the bowl contents are not thoroughly stirred then there will be varying food temperatures throughout the bowl.	<ol style="list-style-type: none"> 1 Allow time for the ingredients to be thoroughly mixed. 2 Increase the stir speed.
Difficult to shut mixer head with food in bowl.	Firm ingredients such as chocolate in the bottom of the bowl prevent the mixer head from locking down.	Add ingredients after the mixer head is lowered.
Mixer runs continuously when stir (2) or stir (3) are selected.	Outlet covers are incorrectly fitted.	Ensure the outlet covers are correctly fitted.
Motor speed is limited when using attachments	Hot bowl fitted.	Remove the bowl, or cool the bowl to below 60°C.

optional attachments available

To buy an attachment not included in your pack, see service and customer care.

attachment attachment code

flat pasta maker ① AT970A

additional pasta attachments
(not shown) used in conjunction
with AT970A

AT971A tagliatelle

AT972A tagliolini

AT973A trenette

AT974A spaghetti

pasta maker ② AT910 comes with maccheroni rigati die

(12 optional dies plus biscuit maker can be fitted)

roto food cutter ③ AT643 comes with 5 drums

fruit press ④ AT644

multi food grinder ⑤ AT950A comes with

a large sausage nozzle

b small sausage nozzle

c kebbe maker

grain mill ⑥ AT941A

food processor ⑦ AT640 includes 3 cutting plates as standard and a knife blade (plates a, b and c can be purchased separately)

pro slicer grater ⑧ AT340

citrus press ⑨ AT312

blender ⑩ 1.5 l acrylic **AT337**, 1.5 l glass **AT338**, 1.5 l stainless steel **AT339**

mini chopper/mill ⑪ AT320A comes with 4 glass jars and 4 lids for storage

continuous juicer ⑫ AT641

stainless steel bowl ⑬ 36386A

Cooking Chef bowl ⑭ 37575

scale ⑮ AT750

colander and sieve ⑯ AT930A

potato peeler ⑰ AT445

The Cooking Chef is not compatible with the following attachments:-

- Major flexible beater 44002
- ice cream maker AT957A
- Kenlyte round bowl 26538A

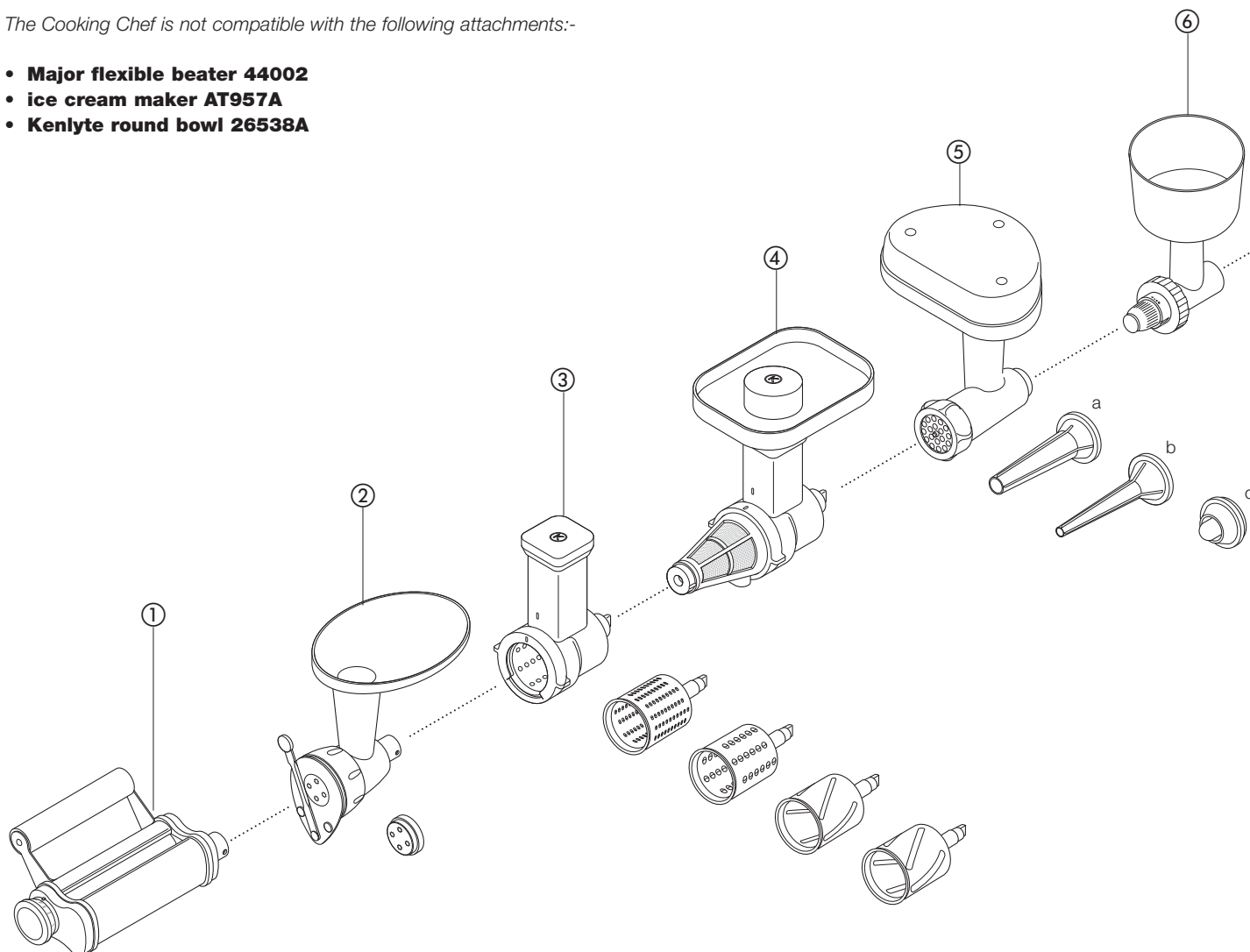

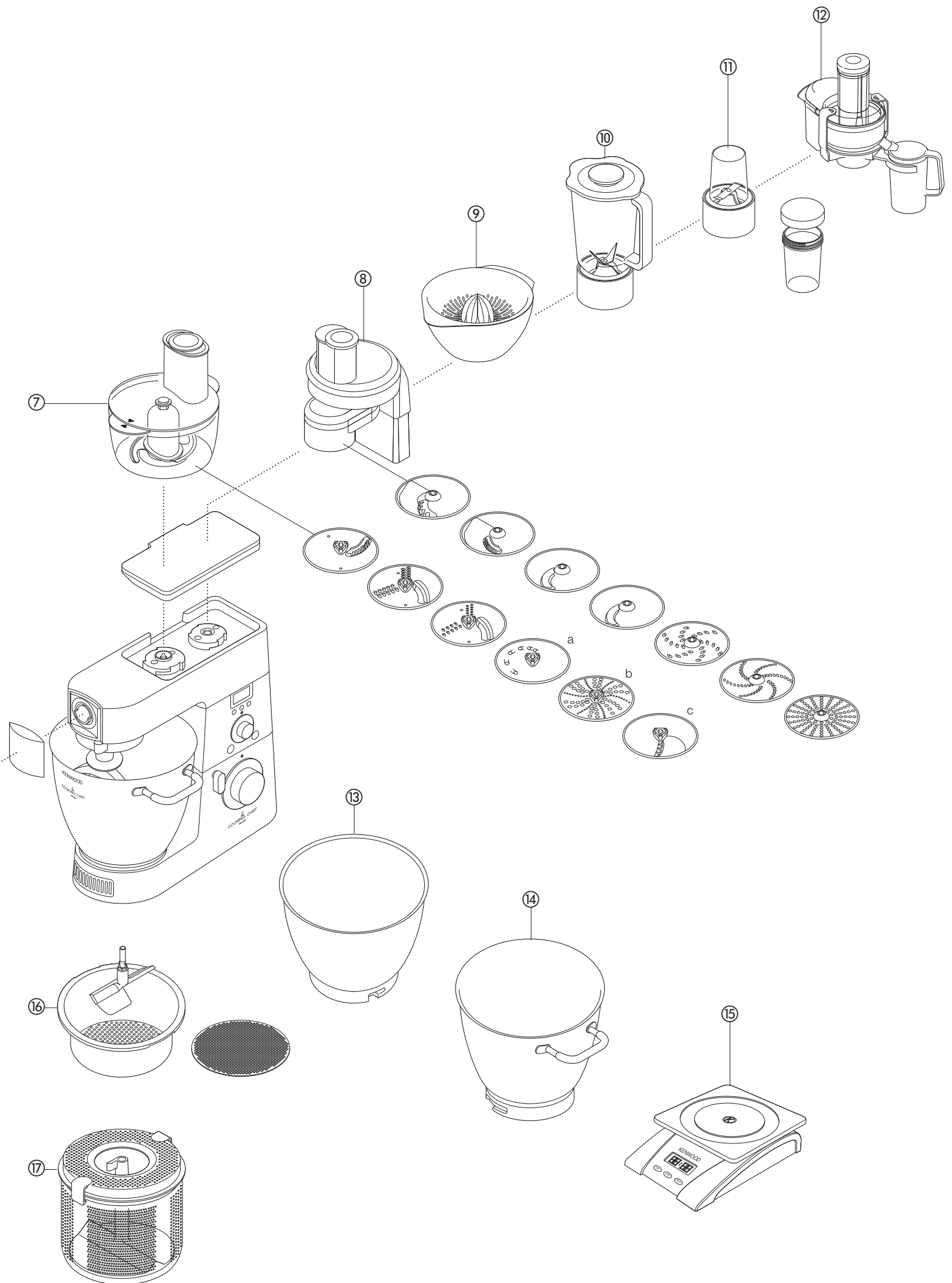

cleaning and service

care and cleaning

- Always switch off and unplug before cleaning.
- A little grease may appear at **outlet 2** when you first use it. This is normal - just wipe it off.
- The metal surfaces of the temperature sensors may show signs of wear during normal use. this does not affect the performance of the product.
- Do not leave the high temperature flexible beater fitted to the mixer when not in use.

appliance, outlet covers

- Wipe with a damp cloth, then dry.
- Never use abrasives or immerse in water.

high temperature flexible beater

- Always remove the flexible wipers after use for cleaning and storage: Firmly pull and twist each wiper until it slides off the stainless steel beater arm.
- To clean the stainless steel beater arm simply remove the flexible wipers and wash by hand in hot soapy water and dry thoroughly. The flexible wipers should be cleaned immediately after use by hand in hot soapy water. Use the cleaning brush supplied to clean **INSIDE** each wiper. Rinse the flexible wipers under hot running tap water and dry thoroughly.
- To refit the flexible wipers, lubricate the stainless steel beater arms with a small amount of fresh cooking oil. Slide the flexible wipers onto the stainless steel arm. Ensure each wiper covers the full length of the arm and is past the tip at the end. Repeat the process for the second wiper. Note: the tool should only be used with both wipers fitted.

bowl, tools, splashguard

- Wash by hand, then dry thoroughly or wash in the dishwasher.
- Never use a wire brush, steel wool or bleach to clean your stainless steel bowl. Use vinegar or a suitable descaler to remove limescale.
- If food sticks or burns on the inside of the bowl, remove as much as possible using the spatula provided. Fill the bowl with warm soapy water and allow to soak. Remove any stubborn deposits using a nylon brush.
- Any discolouration of the bowl will not affect its performance.

drain hole

- Ensure this area is free from food. If necessary use a pipe cleaner or cotton bud to clean.

temperature sensors

- Wipe with a damp cloth then dry thoroughly. Never use abrasives or sharp instruments to clean the sensors.

service and customer care

- If the cord is damaged it must, for safety reasons, be replaced by KENWOOD or an authorised KENWOOD repairer.

UK If you need help with:

- using your machine
- servicing or repairs (in or out of guarantee)

☎ call KENWOOD Customer Care on **023 92392333**.

Have your model number ready - it's on the underside of the mixer.

- spares and attachments

☎ call **0870 2413653**.

other countries

- Contact the shop where you bought your machine.

- Designed and engineered by Kenwood in the UK.
- Made in China.

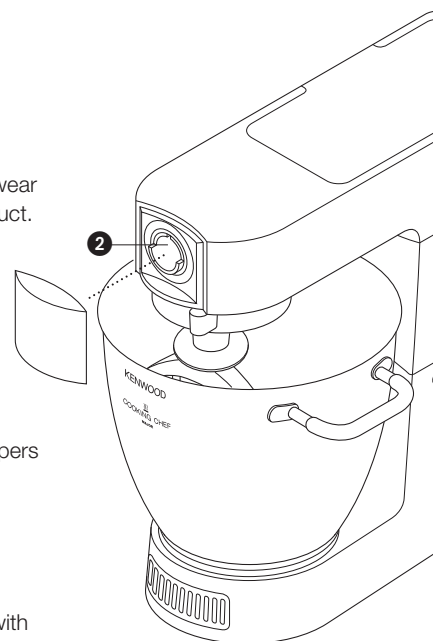



IMPORTANT INFORMATION FOR CORRECT DISPOSAL OF THE PRODUCT IN ACCORDANCE WITH EC DIRECTIVE 2002/96/EC.

At the end of its working life, the product must not be disposed of as urban waste.

It must be taken to a special local authority differentiated waste collection centre or to a dealer providing this service.

Disposing of a household appliance separately avoids possible negative consequences for the environment and health deriving from inappropriate disposal and enables the constituent materials to be recovered to obtain significant savings in energy and resources. As a reminder of the need to dispose of household appliances separately, the product is marked with a crossed-out wheeled dustbin.

guarantee UK only

- If your machine goes wrong within one year from the date you bought it, we will repair or replace it free of charge provided:
- you have not misused, neglected or damaged it;
- it has not been modified;
- it is not second-hand;
- it has not been used commercially;
- you have not fitted a plug incorrectly; and
- **you supply your receipt to show when you bought it.**

This guarantee does not affect your statutory rights.

recipes

See important points for bread making on page 13.

- white bread stiff yeast dough**
- ingredients
- 1.36kg (3lb) strong plain flour
 - 15ml (3tsp) salt
 - 25g (1oz) fresh yeast; or 15g/20ml (½oz) dried yeast + 5ml (1tsp) sugar
 - 750ml (1¼pts) warm water: 43°C (110°F). Use a thermometer or add 250ml (9fl oz) boiling water to 500ml (18fl oz) cold water
 - 25g (1oz) lard
- method
- 1 **dried yeast** (the type that needs reconstituting): pour the warm water into the bowl. Then add the yeast and the sugar and leave to stand for about 10 minutes until frothy.
fresh yeast: crumble into the flour.
other types of yeast: follow the manufacturer's instructions.
 - 2 Pour the liquid into the bowl. Then add the flour (with fresh yeast if used), salt and lard.
 - 3 Knead at minimum speed for 45 - 60 seconds. Then increase to speed 1, adding more flour if necessary, until a dough has formed.
 - 4 Knead for 3 - 4 more minutes at speed 1 until the dough is smooth, elastic and leaves the sides of the bowl clean.
 - 5 Put the dough into a greased polythene bag or a bowl covered with a tea towel. Then leave somewhere warm until doubled in size.
 - 6 Re-knead for 2 minutes at speed 1.
 - 7 Half fill four 450g (1lb) greased tins with the dough, or shape it into rolls. Then cover with a tea towel and leave somewhere warm until doubled in size.
 - 8 Bake at 230°C/450°F/Gas Mark 8 for 30 - 35 minutes *for loaves* or 10 - 15 minutes *for rolls*.
- When ready, the bread should sound hollow when tapped on the base.
- white bread soft yeast dough**
- 2.6kg (5lb 12oz) ordinary plain flour
 - 1.3 litre (2¼pts) milk
 - 300g (10oz) sugar
 - 450g (1lb) margarine
 - 100g (4oz) fresh yeast or 50g (2oz) dried yeast
 - 6 eggs, beaten
 - 5 pinches salt
- method
- 1 Melt the margarine in the milk and bring to 43°C (110°F).
 - 2 **dried yeast** (the type that needs reconstituting): add the yeast and sugar to the milk and leave to stand for about 10 minutes until frothy.
fresh yeast: crumble into the flour and add the sugar.
other types of yeast: follow the manufacturer's instructions.
 - 3 Pour the milk into the bowl. Add the beaten eggs and 2kg (4lb 6oz) flour.
 - 4 Mix at minimum speed for 1 minute, then at speed 1 for a further minute. Scrape down.
 - 5 Add the remaining flour and mix at minimum speed for 1 minute, then at speed 1 for 2 - 3 minutes until smooth and evenly mixed.
 - 6 Half fill some 450g (1lb) greased tins with the dough, or shape it into rolls. Then cover with a tea towel and leave somewhere warm until doubled in size.
 - 7 Bake at 200°C/400°F/Gas Mark 6 for 20 - 25 minutes *for loaves* or 15 minutes *for rolls*.
 - 8 When ready, the bread should sound hollow when tapped on the base.
- Makes about 10 loaves.

recipes *continued*

strawberry and apricot gâteau

- ingredients: sponge
- 3 eggs
 - 75g (3oz) caster sugar
 - 75g (3oz) plain flour
- filling and decoration
- 150ml (¼pt) double cream
 - Sugar to taste
 - 225g (8oz) strawberries
 - 225g (8oz) apricots
- method
- 1 Halve the apricots and remove the stones. Cook gently in very little water, adding sugar to taste, until soft.
 - 2 Wash and halve the strawberries.
 - 3 To make the sponge, whisk the eggs and sugar at maximum speed until very pale and thick.
 - 4 Remove the bowl and the whisk. Fold in the flour by hand using a large metal spoon - do this carefully to keep the sponge light.
 - 5 Put the mixture into two 18cm (7") greased and lined sandwich tins.
 - 6 Bake at 180°C/350°F/Gas Mark 4 for about 20 minutes until the cake springs back when lightly touched.
 - 7 Turn out onto a wire rack.
 - 8 Whisk the cream at maximum speed until stiff. Add sugar to taste.
 - 9 Roughly chop the apricots and a third of the strawberries. Fold them into half the cream.
 - 10 Spread this over one of the sponges, then put the other sponge on top.
 - 11 Spread the remaining cream on top and decorate with the remaining strawberries.

meringues

- ingredients
- 4 egg whites
 - 250g (9oz) icing sugar, sieved
 - Line your baking tray with non-stick baking parchment.
- method
- 1 Whisk the egg whites and sugar at maximum speed for about 10 minutes until it stands in peaks.
 - 2 Spoon the mixture onto the baking tray (or use a piping bag with a 2.5cm (1") star nozzle).
 - 3 Bake at 110°C/225°F/Gas Mark ¼ for about 4 - 5 hours until firm and crisp. If they start to brown, leave the oven door slightly ajar.
- Store meringues in an airtight tin.

shortcrust pastry

- ingredients
- 450g (1lb) flour, sieved with the salt
 - 5ml (1tsp) salt
 - 225g (8oz) fat (mix lard and margarine straight from the fridge)
 - About 80ml (4tbsp) water
- hint
- Don't overmix
- method
- 1 Put the flour into the bowl. Chop the fat up roughly and add to the flour.
 - 2 Using the stainless steel K beater mix at speed 1 until it resembles breadcrumbs. Stop before it looks greasy.
 - 3 Add the water and mix at minimum speed. Stop as soon as the water is incorporated.
 - 4 Cook at around 200°C/400°F/Gas Mark 6, depending on the filling.

chilli marinade

- Ingredients
- 200g (7oz) cold clear honey (refrigerated overnight)
 - 1 green chilli (whole)
 - 5ml (1 tsp) crunchy peanut butter
 - seasoning
- method
- 1 Place all the ingredients into the mini chopper/mill.
 - 2 Fit the attachment to the mixer and allow the ingredients to settle around the blade.
 - 3 Switch to pulse for 10 seconds.
 - 4 Use as required.

Head Office Address:
Kenwood Limited, New Lane, Havant, Hampshire PO9 2NH, UK
www.kenwoodworld.com
Designed and engineered by Kenwood in the UK
Made in China

